

KEY BOARD SWITCHES



Series 13

DESCRIPTION

Integral Key Switch Series 13, satisfies the user requirement for a low profile, high quality switch with a smooth tactile feel. The design of the contacts using special copper alloy, ensure a very high force per unit area and reduced susceptibility to contact closure interference from foreign particles.

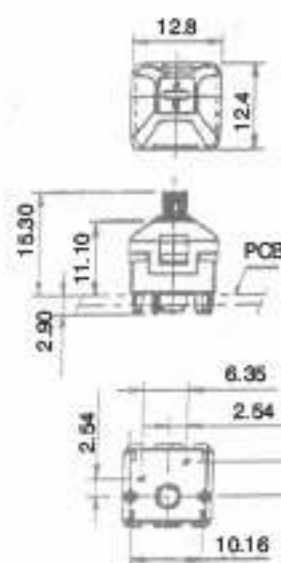

DIMENSIONAL DETAILS

KEY TOP

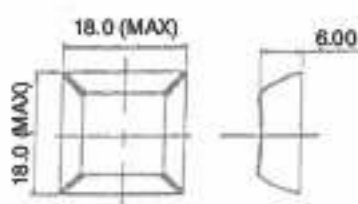

KEY TOP COLOURS

1. WHITE
2. BLACK
3. RED
4. GREY

Available only in 18 mm

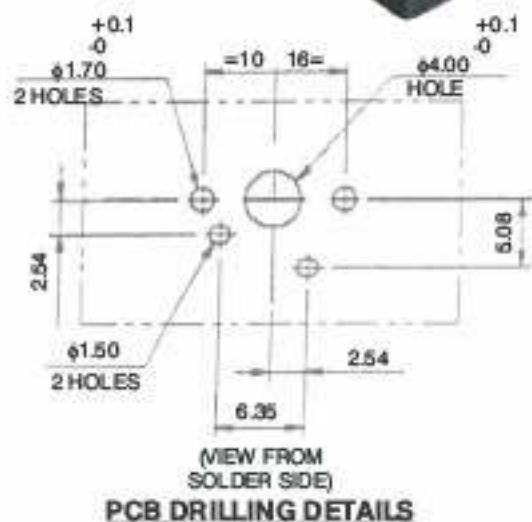

All Dimensions in mm.

SPECIFICATIONS :

CONTACT RATING	: 0.1 AMP @ 30 Volts AC/DC
CONTACT RESISTANCE	: <30 mill ohms initial at 2-6 V DC
INSULATION RESISTANCE	: >100 M ohms
INSULATION DIELECTRIC	: 250 V AC (applied for 1 minute)
BOUNCETIME	: 5 ms or less.
ACTUATING FORCE	: 70 grms.
OPERATING TEMP RANGE	: -25°C to +85°C
TOTAL TRAVEL	: 4.00
PRETRAVEL	: 2.00 ± 0.60
LIFE	: 20 million cycles @ 12VDC/1 mA.

MATERIALS & FINISHES

COVER / BASE	: Glass filled PBT (UL approved)
PLUNGER	: Acetal (Delrin)
KEY TOP	: ABS
STATOR & MOVING CONTACTS	: Copper Alloy Hard Silver Plated
SPRING	: Stainless Steel Wire
MOUNTING	: On PCB only